

OWNER ' S MANUAL



FREEDOM 458 Series COMBI™ INVERTER/CHARGER



Model 10

Model 15

Model 20

Model 25

Model 30

*Manual includes all models of Freedom 458 Inverter/Charger



INFORMATION IN THIS MANUAL IS SUBJECT TO CHANGE WITHOUT NOTICE



Thank you for purchasing a Heart Interface Freedom 458 Series Combi[™] Inverter/Charger. Heart Interface takes pride in manufacturing quality products specifically designed to meet your power requirements.

Freedom Combi Inverter/Chargers provide silent, efficient and reliable AC power for a variety of applications. They feature "hands-free" operation, automatic 3-stage battery charging and automatic AC transfer switching. For your convenience, service is available world-wide by qualified service centers.

If you have any questions about your Freedom Combi, please contact Heart Interface toll free: **(800) 446-6180**.

For technical support and additional information about Heart Interface products, visit our web site at **www.heartinterface.com** or send us e-mail:

techhelp@heartinterface.com

sales@heartinterface.com

SAFETY SUMMARY

Safety information for installation and operation is contained throughout this manual where it applies and is not included in this summary.

Definitions:

Warning statements identify conditions or practices which could result in personal injury, loss of life, damage to equipment or other property.

Fuse Replacement For continued protection against the possibility of fire, replace the fuse only with a fuse of the specified voltage, current and type ratings.

Power Source To avoid damage, operate the equipment only within the specified AC (line) and DC (battery) voltages.

Servicing To reduce the risk of electric shock do not open this unit. There are no user serviceable parts inside. Refer all service to qualified personnel.

The statements, specifications and instructions in this publication are believed to be correct. No warranty is made, expressed or implied by the seller or manufacturer with respect to any results or lack thereof from the use of information in this publication and no liability is assumed for any direct or consequential damages, personal loss or injury. All statements made herein are strictly to be used or relied on at the user's risk. © 1998 Heart Interface Corporation. All rights reserved.

TABLE OF CONTENTS

Introduction	4	Troubleshooting	31
Things You Should Know	5	LED Fault Status	
Circuit Breaker Protection		Things to Check	
Thermostat Controlled Cooling		Glossary	33
Inverter Idle Circuit		Specifications	35
Low and High Battery Shutdown		Installation Diagrams	36
Power Sharing		Warranty	48
Temperature Sensitive Charging			
Operation	7		
Optional Remote Control Panels	10		
Batteries	11		
Battery Types			
Battery Interconnection			
Battery Bank Ratings and Sizing			
Battery Charging	15		
Freedom Battery Chargers			
Battery Charger Voltage Table	20		
Installation Precautions	21		
Installation	22		
Key Installation Points			
Grounding			
Neutral Bonding			
AC Wiring			
AC Input			
AC Output			
Ground Fault Circuit Interrupters			
Remote Control Wiring			
TSC Temperature Sensitive Charging			
DC Wiring			
Battery Cable Fusing			
Power ON Checks			

Not recommended for use in marine environment

INTRODUCTION

This owner's manual describes the Freedom 458 Series CombiTM Inverter/Chargers from Heart Interface. These units perform three distinct functions:

1. DC to AC power inverting.
2. Automatic transfer switching between inverter power and incoming AC power.
3. Automatic 3-Stage Battery charging plus manual battery equalizing.

- The inverter provides regulated 120 volt AC power at a crystal controlled frequency from a deep cycle battery bank and is rated at:

Freedom 10	1000 watts
Freedom 15 & 15D	1500 watts
Freedom 20 & 20D	2000 watts
Freedom 25	2500 watts
Freedom 30	3000 watts

The output is a modified sine wave and is compatible with most appliances, tools and other 120 VAC equipment. (Note: Certain laser printers, breadmakers, digital clocks and small battery chargers may not operate on modified sine wave.) An idle mode reduces battery power consumption when loads are removed from the inverter. There is a low battery output protection circuit and momentary surge power of more than twice the inverter rating for starting electric motors. High efficiency insures the longest possible battery life between charges.

- The internal transfer switch allows the Freedom Inverter/Charger to be connected to an external AC source and transfer the source

power through directly to the loads. When the external AC power source is disconnected, the transfer switch allows automatic switching back to the inverter.

The Freedom Inverter/Charger operates as a self-contained backup power system, just add batteries.

- Freedom battery chargers are electronically controlled and rated at a maximum output current:

Freedom 10	50 Amps DC
Freedom 15 & 15D	75 Amps DC
Freedom 20 & 20D	100 Amps DC
Freedom 25	130 Amps DC
Freedom 30	140 Amps DC

They are designed to rapidly and optimally charge wet, gel, or Absorbed Glass Mat (AGM)** cell deep-cycle batteries. Battery charging is automatically accomplished in 3 stages: Bulk Charge, Acceptance Charge and Float Charge.

Using a Remote Control Panel or Link Instrumentation, a manually engaged Equalizing Charge cycle is possible. Simple, automatic operation is made possible by the microprocessor in the Freedom Inverter/Charger. In most cases, no attention or maintenance is required.

Electronic Protection

Fast-acting electronic circuits protect the inverter from overloads and short circuits. Other protection includes a low and high battery voltage cutoff and automatic shutdown if an over temperature condition occurs. When the fault condition is corrected, the unit will automatically reset. Example: remove overload, charge batteries or allow to cool.

**Battery type selection is set on the front of the unit or with an optional remote (Remote Control Panel or Link Instrument).

THINGS YOU SHOULD KNOW

Circuit Breaker Protection

The Freedom Inverter/Charger is supplemental breaker protected.

The INVERT/CHARGE breaker on the front of the unit protects against sustained inverter/charger over current conditions.

These breakers are reset by pushing the button back in.

The output circuit breakers protect the output AC circuits. Models are available with one or two outputs.

Thermostat Controlled Cooling

Freedom Inverter/Chargers are equipped with a thermostatically-controlled fan that cools the unit so it can operate continually at its rated

Circuit Breaker Protection			
	INV/CHG	OUT 1	OUT 2
10	15	N/A	N/A
15	20	N/A	N/A
15D	20	15/20*	15/20*
20	25	N/A	N/A
20D	25	15/20*	15/20*
25	30	N/A	N/A
30	30	N/A	N/A

*Circuit breaker configurations include 15/15, 15/20, and 20/20

*Note: Supplemental circuit breakers are reset by pushing the button back in. The fault must be removed before resetting the circuit breaker. Integral branch circuit rated breakers are reset by setting the appropriate breaker switch to the "on" position. The fault must be removed before resetting the circuit breaker

If a 30-Ampere service supplies the input to the unit, a model with integral branch circuit rated breakers allows direct wiring from the unit to the load.

Units with only supplemental circuit breakers between the unit and the load. Appropriate wire gauges must be used throughout the installation. Refer to NEC specifications.

Inverter Idle Circuit

This automatic energy saving feature reduces battery power consumption when no AC load is present. Response from idle is instantaneous. In most cases, the operation of the idle circuit is not noticeable. Use of the Remote Control Panel or Link Instrumentation allows the idle threshold to be adjusted. The unit does not put out 120 volts when in idle. To bring the unit out of the idle condition, apply a load.

Low and High Battery Shutdown

When in inverter mode, if the battery voltage drops to 10.0 volts, the inverter will automatically shut off. Charge the batteries to 13.5 volts to automatically resume operation.

Voltage shut down also occurs for a high battery condition at 15.5 volts. Operation will resume automatically when the battery voltage drops below 15.5 volts. Check all DC sources on the system for the reason for the excessive voltage.

Power Sharing

When connected to an external AC source the battery charger and transfer functions are engaged. A unique Power Sharing feature automatically reduces the AC power consumption of the battery charger allowing necessary AC power to go to the load. This prevents the source AC INPUT circuit breaker from tripping within the specified rating of the AC circuit breaker.

The Power Sharing set point of each unit has a factory default setting of 30 Amps. This can be changed using the Remote Control Panel or Link Instrumentation.

THINGS YOU SHOULD KNOW

Freedom 458 Series Combi with Branch Circuit Rated Breakers

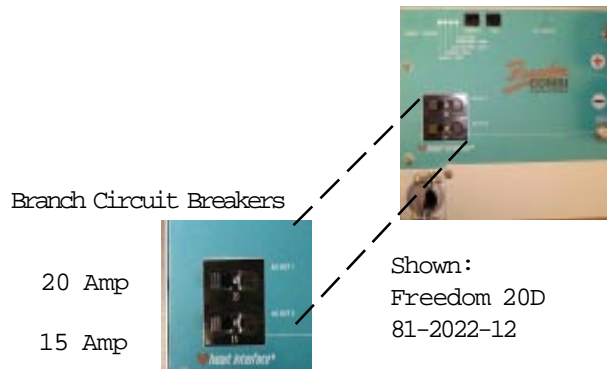

Integral Branch Circuit Rated Breakers Models 15D&20D

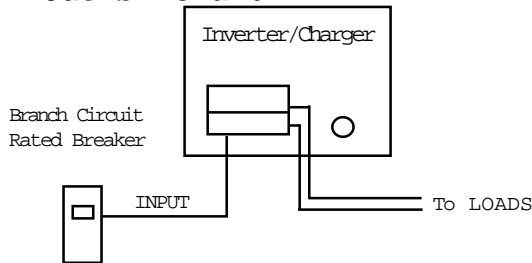

Units with integral branch circuit rated breaker protection require a branch circuit rated breaker at the input only. The output to two branch loads may be connected directly at the unit output.

NOTE: The INPUT branch rated circuit breaker may be at the source of AC power (i.e. shore power or generator or from a main AC distribution panel located before the input of the unit).

Supplemental Branch Circuit Rated Breakers

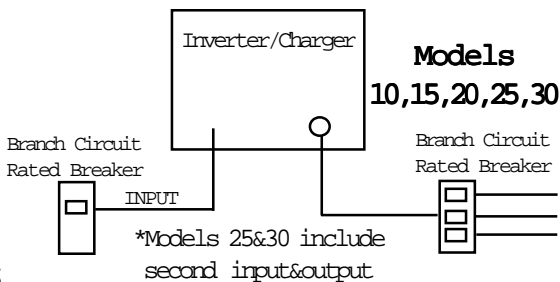

Temperature Sensitive Charging

When the supplied battery temperature sensor is connected to the unit and the batteries, the charge voltage is controlled based on battery temperature. The charger adjusts the charge voltage to the best level, minimizing water loss in wet cell batteries. Charge voltage regulation optimizes the battery life cycle.

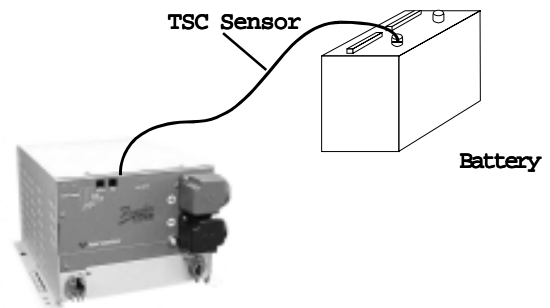

OPERATION

The Freedom Inverter/Charger provides 120 volt AC power from auxiliary DC batteries, automatic battery charging and automatic AC transfer switching between an external AC source and inverter mode.

External AC Power

When external AC power is available, the 3-stage battery charger, transfer switching, and Power Sharing automatically function.

When external AC power is not available and the INVERT switch is ON (either through the auxiliary switch or the INVERT button on the remote), the inverter will automatically turn ON. If the INVERT switch is OFF (the INVERT LED will not be illuminated), the inverter will be OFF.

If installed with the Remote Control Panel or Link Instrumentation, the unit will be set up and controlled from the remote. Refer to the remote manual for more information.

Front Panel Controls and Indicators

INVERT MODE

The INVERT push-button switch is located on the front of the unit and has two functions:

- Turn the inverter ON/OFF and reset after a fault condition. Pressing the INVERT switch turns the inverter ON. The green INVERT LED will be ON when the inverter is inverting. When the inverter is ON, pressing the INVERT switch turns the inverter OFF.

INVERT

CHARGE

- Battery type setup. To enter the battery

OPERATION

STATUS LEDs

Each Status LED performs two functions, providing battery type selection and operation status.

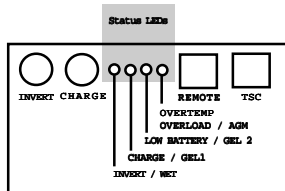

Battery Type Selection

After holding the INVERT button down for 5 seconds, use the CHARGE button to select battery type :

WET GEL 1 GEL 2 AGM

Operation Status

INVERT - Green LED

The INVERT push-button switch is located on the front of the unit.

- When the LED is solid green, the unit is in invert mode. This occurs by pressing the INVERT switch for (3-5 seconds).
- When the LED is blinking slowly (1 time per second), the inverter is in standby with AC power applied and the transfer switch engaged
- Press the INVERT switch again to turn the inverter OFF.

CHARGE - Green LED

- The CHARGE push-button switch is located on the front of the unit.

When external AC is applied to the AC input of the unit, the charger automatically turns ON. The CHARGE LED will be solid green.

- When the LED is blinking slowly, (1 time per second) the charger is ready, but external AC power is not available.
- Press the CHARGE switch again to turn

the charger OFF. The charger defaults to ON when operation without a remote or with the Freedom Remote Control Panel.

- When the LED is OFF, the charger has been manually turned OFF. This can only be accomplished while AC power is being supplied.

NOTE: When AC power is available, the default setting for the charger is ON. If the unit was manually turned OFF and AC power is interrupted and becomes available again, the charger will return to ON.

LOW BATTERY - Red LED

- When the LED is OFF the battery voltage is normal, between 10.5 and 15.0 volts DC.
- When the LED is solid red, it indicates a battery warning condition, the battery voltage is below 10.5 volts DC or above 15.0 volts DC.
- When the LED is blinking slowly, (1 time per second), a battery shutdown has occurred. The voltage is either below 10.0 volts DC or above 15.5 volts DC.
- When the LED is blinking rapidly (5 times per second), a potential problem in the DC system has been detected. Check your batteries, battery cables and DC loads.

OVERTEMP/OVERLOAD - Red LED

- When the LED is Off operation is normal.
- When the LED is red, there is an over temp or overload condition. Check for excessive loads or short circuit on the output of the inverter. Correct the condition and restart by pushing the INVERT switch.

OPERATION

- When the LED is blinking slowly (1 time per second), an over current condition or a short circuit has occurred. The system has shut OFF and will not automatically restart. Correct the fault condition and manually restart the system.

LOW BATTERY & OVERTEMP/OVERLOAD

- Red LEDs

- When both LEDs are blinking, an AC backfeed has been detected. A backfeed occurs when AC power from an external source is connected to the output of the inverter. Inspect wiring for possible input/output wiring error. This condition will damage the unit and must be corrected before further operation.

TSC (Temperature Sensitive Charging)

This provides for the connection of a sensor to measure battery temperature for compensated charging. If no sensor is connected the charge voltage levels are set to defaults based on battery type.

OPTIONAL REMOTES

If using one of the remotes, refer to the installation instructions included with the remote.

Note: When a Remote Control Panel or Link is installed, the jumper included in the parts plastic bag is **not** used in the Auxiliary Switch Port (AUX SWITCH) on the front panel of the inverter/charger. See page 23 for more details.

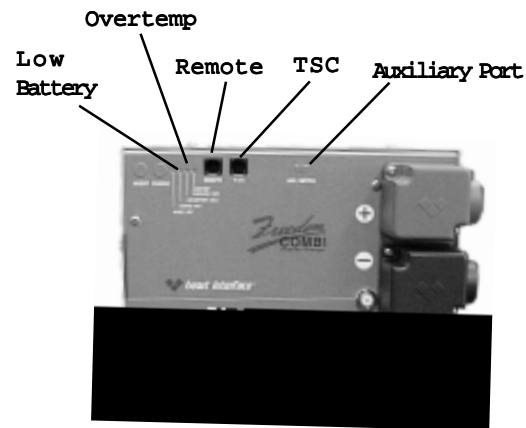

OPTIONAL REMOTE CONTROL PANELS

Remote Control Panel

An optional remote control panel is available. The LED bargraphs on the remote control panel shows battery voltage and DC current in both inverter and charger modes.

Easy to see red, yellow and green LEDs show the battery state-of-charge. Power Sharing, charger ON/OFF, inverter ON/OFF controls are provided. Set up features include selection of Idle Threshold, Battery Type and Battery Capacity.



Remote Control Panel

Advanced Remote Control Panels Link Instrument

Advanced remote control panels are also available: the Link 1000, 2000 and 2000R.

LINK 1000

Link 1000 controls the Freedom Inverter/Charger and provides complete battery state-of-charge information including DC voltage, current, Amp-hours consumed, Time Remaining and historical data for a single battery bank.

LINK 1000



LINK 2000

The Link 2000 has the same features as the Link 1000, providing inverter/charger control and complete battery state-of-charge information. It monitors two battery banks.

LINK 2000



LINK 2000R

The Link 2000R adds the ability to regulate an engine-driven alternator. The precision regulator in the LINK 2000R allows the alternator to be controlled as a 3-stage battery charging system.

If Link Instrument is used to control the inverter/charger, refer to the Link Owner's Manual for setup and control information.

Refer to the Remote Control Panel or LINK Owner's Manual for installation and operation instructions

The jumper is not installed in the AUX Switch Port on the front panel of the inverter when the Remote Control Panel or Link Instrument is used. See page 23 for more details.

BATTERIES

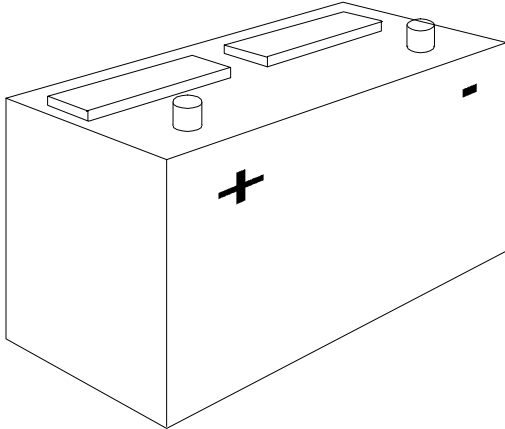

BATTERY TYPES

Use only deep-cycle batteries with your Freedom Inverter/Charger. These fall into three broad categories: wet cell, gel cell and Advanced AGM (Absorbed Glass Mat) batteries.

Wet Cell Batteries

True deep-cycle wet cell batteries are characterized by relatively thick internal plates that are alloyed with antimony.

Common 12 volt marine/RV deep-cycle batteries are acceptable. Golf cart batteries perform well and may have a longer life. These 6 volt batteries must be used in series connected in pairs. **High quality deep-cycle batteries offer good performance** and are available in a wide variety of sizes.

Wet cell batteries will give off gas as a natural result of charging and will experience some water loss. It is **very important that the electrolyte level be checked frequently** and topped off with distilled water when necessary. Follow the battery manufacturer's recommendations for maintenance.

Never allow the top of the battery plates to be exposed to air, as contamination of the cell will result. Keep the top of batteries clean. Always provide adequate ventilation for the battery storage compartment.

Do not use ordinary car batteries or engine starting batteries with your inverter/charger. Beware of any battery that is rated in Cold Cranking Amps (CCA). This is a rating which applies only to engine starting batteries. In general, most wet cell batteries that are described as hybrid type batteries, suitable for either engine starting or deep-cycle applications, are a compromise and will have limited life if deeply discharged.

BATTERIES

Beware of so-called maintenance-free batteries. These batteries have calcium alloyed with the lead and hold the liquid electrolyte in a sponge-like material. They are sealed and water can not be added. Do not confuse them with true gel cell or AGM batteries, they will not hold up well to deep discharging and repeated cycling.

Gel Cell Batteries

Gel cell batteries are lead-acid batteries similar in many ways to the common wet cell battery, but differences in the chemistry and construction provide some unique features.

- No Maintenance
- Low Self-Discharge Rate
- Low Internal Resistance

Even though gel cells are sealed batteries, the battery compartment should still be ventilated.

Advanced AGM (Absorbed Glass Mat) Batteries

This battery is lead acid but maintenance-free. The performance is similar to gel cell batteries. The charge parameters are similar to wet cell batteries.

Battery Selection

The most important feature to consider in making your battery selection is to select true deep cycle batteries rated in Amp-hours (AH) and sized to match your power requirements.

BATTERY INTERCONNECTION

In most cases, you will be using a bank of two or more batteries with your inverter/charger. You may connect batteries together in two configurations, series and parallel depending on their voltage.

Series

Connecting two batteries in series will double the voltage of the battery bank. For instance, two 6 volt batteries connected in series will produce 12 volts. The Amp-hour capacity of the battery bank will be the same as each individual battery. Example, two 6 volt 220 Amp-hour batteries in series will produce one 12 volt 220 Amp-hour battery bank.

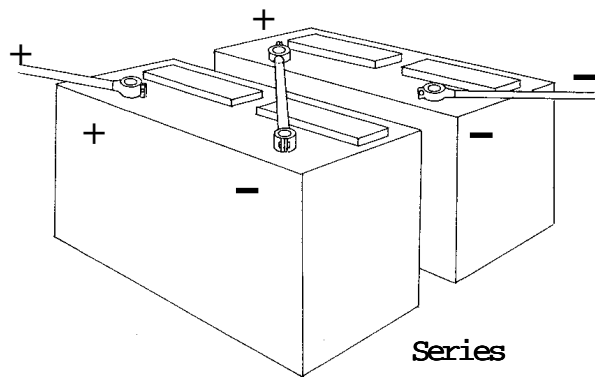

Series Increase Voltage

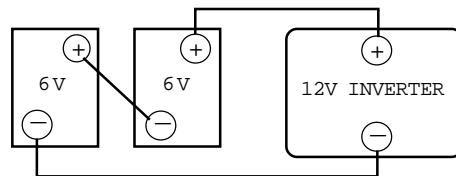

EACH BATTERY
CAPACITY:
220
AMP-HOURS
@ 6 VDC

TOTAL BATTERY
BANK CAPACITY:
220
AMP-HOURS
@ 12 VDC

BATTERIES

Parallel

Connecting two batteries in parallel will double the Amp-hour rating of the battery bank, while the voltage will be the same as each individual battery. Example, two 12 volt 105 Amp-hour batteries in parallel will produce one 12 volt 210 Amp-hour battery bank.

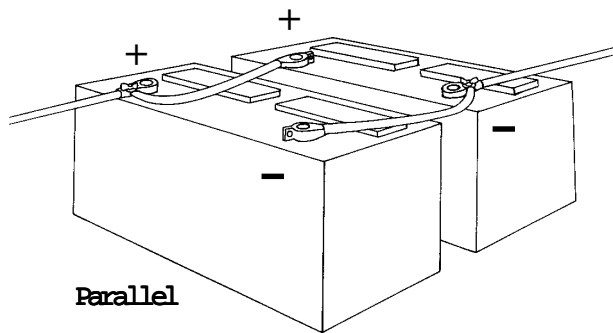

Parallel Increase Amp-hour Capacity

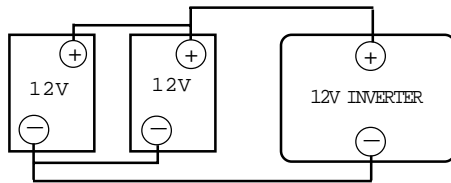

EACH BATTERY
CAPACITY:
105
AMP-HOURS
@ 12 VDC

TOTAL BATTERY
BANK CAPACITY:
210
AMP-HOURS
@ 12 VDC

Only similar batteries should be connected together in one bank. Do not connect old and new batteries together or wet and gel cell batteries together. In the above drawing, the load is connected to the positive terminal of the first battery and the negative terminal of the last battery. This practice helps to balance the battery bank and is called *cross-connecting* the battery bank.

Note: It is not advisable to connect batteries of different case sizes or Amp-hour ratings in the same battery bank.

Always use properly sized wire and terminals for your interconnecting battery cables. For size information refer to NEC requirements or contact your local electrician.

BATTERY BANK RATINGS AND SIZING

Deep-cycle batteries are usually rated in Amp-hours. The Amp-hour rating is based on a 20-hour discharge rate, therefore, a 100 Amp-hour battery can deliver 5 Amps for 20 hours. If the discharge rate is greater than 5 Amps, the available Amp-hours are decreased. For example, if the load is increased to 100 Amps, only about 45 Amp-hours will be available at this rate of discharge.

Deep-cycle batteries can be discharged about 80% of capacity before damage occurs. Shallow cycling will result in much longer battery life. Calculating a battery bank size based on 50% discharge cycling is generally considered to be a good compromise between long battery life and size.

BATTERIES

To achieve 50% cycling you should calculate your Amp-hour consumption between charging cycles and use a battery bank with twice that capacity**. Each AC appliance or tool has a rating plate on it and will be rated in either AC Amps or Watts or AC VA (Volt-Amps) apparent power. To calculate Amp-hour consumption, use one of the formulas to the right to calculate the DC Amp-hour draw for a 12 volt system.

Calculate the Amp-hours for every AC appliance or tool that will be operated on the inverter. This will provide the total number of Amp-hours used between recharges. Size the battery bank using this number as a guideline. A good rule to follow is to size the battery bank a minimum of 2 times larger than the total Amp-hour load requirement. Plan on recharging when 50% discharged.

**Batteries are typically charged to 85% of full charge when charging with alternators without 3-stage regulators.

AMP-HOUR CONSUMPTION FORMULAS

$(AC\ Amps \times 10) \times 1.1 \times \text{hours of operation} = DC\ Amp\text{-hours}$

$(Watts / DC\ Voltage) \times 1.1 \times \text{hours of operation} = DC\ Amp\text{-hours}$

$(AC\ VA / DC\ Voltage) \times 1.1 \times \text{hours of operation} = DC\ Amp\text{-hours}$

DC Voltage is 12, 24 or 32 depending on your system.

In all formulas, 1.1 is the correction factor for inverter efficiency.

Typical Power Consumption

The chart identifies typical power consumption for common AC loads. Use it as a guide when identifying your power requirements.

Many electric motors have momentary starting requirements well above their operational rating. Start up watts are listed where appropriate. Individual styles and brands of appliances may vary.

If using the same battery bank for the inverter and other DC loads, be sure to consider the power consumption of the DC loads when sizing the battery bank.

Typical Power Consumption									
Appliance	Typical Wattage	Appliance Run Times / Amp Hours							
		5 M in.	15 M in.	30 M in.	1 Hr.	2 Hr.	3 Hr.	8 Hr.	24 Hr.
13" Color TV	50	.33	1	2	4	8	12	32	96
19" Color TV	100	.66	2	4	8	16	24	64	192
VCR	50	.33	1	2	4	8	12	32	96
Lamp	100	.66	2	4	8	16	24	64	192
Blender	300	2	6	12					
Laptop Computer	50	.33	1	2	4	8			
Curling Iron	50	.33	1	2					
3/8 Power Drill	500	3.3	10	20					
Ice maker*	200			2.6	5.2	10.4	15.6	41.6	83.2
Coffee Maker	1000	6.6	20	40	80	160			
3 cu' Refrigerator*	150			2	4	8	12	32	96
20 cu' Refrigerator*	750			21	42	84	126	336	672
Compact Microwave	750	5	15	30	60	120	180		
Full Size Microwave	1500	10	30	60	120	240	360		
Vacuum	1100	7.3	22	44	88	176	264		

Number in each box represents the total Amp hours used (@ 12 volt DC) based on various continuous run times.
*Note refrigeration is typically calculated using a 1/3-duty cycle.

NOTE Certain laser printers, breadmakers, digital clocks and appliance/tool chargers may not operate on modified sine wave.

BATTERY CHARGING

Battery Charging

Completely charging wet cell deep-cycle batteries requires the battery voltage to be raised beyond what is known as the gassing point. This is the voltage at which the battery begins to bubble and gas is given off. If charging stops short of this point, sulfate is left on the plates and deterioration of the battery begins. The gassing point will vary with battery temperature.

At 77 degrees F, the gassing point of a 12 volt battery is about 14.0 volts.

AGM and Gel cell batteries must not be charged to their gassing point. In fact, high voltage charging which gasses these batteries is harmful to them. They typically require a lower bulk charge voltage and a higher float voltage than wet cell batteries. Consult the battery manufacturer for specifications.

Freedom Battery Chargers

Freedom battery chargers are designed to overcome the limitations of conventional chargers by utilizing 3 distinct charge stages, each designed for optimal charging of wet, gel cell and AGM deep-cycle batteries. Battery type selection is made on the front panel of the inverter/charger or through the Remote Control Panel or a Link Instrumentation. For more information on battery type selection, see page 7 or refer to the Remote Control Panel manual.

BATTERY CHARGING

Benefits of the Freedom Charger vs. the traditional taper charger

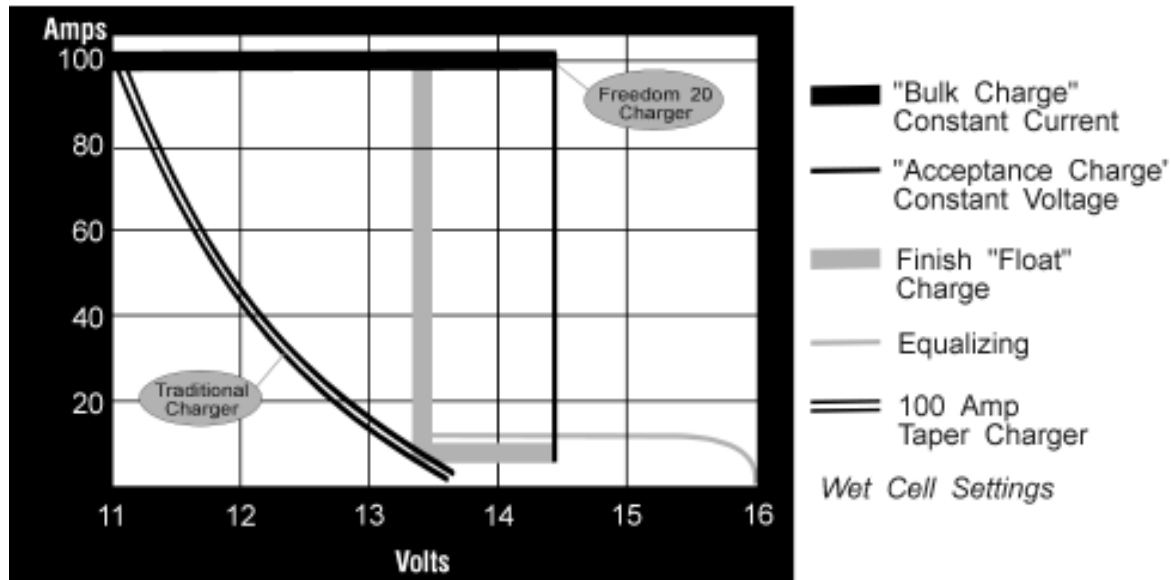

Quicker more complete recharging, safe long term charging and battery rejuvenation through an equalizing charge. (Wet cell settings.)

NOTE: Freedom battery chargers are ON whenever AC power is connected to the charger input. The charger can be turned OFF using the CHARGE switch on the front of the unit. This sequence will occur each time external AC power is available. The charger can be turned ON/OFF using the Remote Control Panel or Link Instrumentation.

Each time the battery charger is engaged, the 3-stage charger proceeds automatically, resulting in an efficient complete charge and safe battery maintenance. Use of the Remote Control Panel or Link Instrument provides the ability to periodically apply an equalizing charge.

Refer to Remote Control Panel or the Link Instrument Owner's Manual for more information.

The battery charger stages are:

Stage 1 - Bulk Charge During the bulk charge stage most of the energy that has been consumed during discharge is returned to the battery bank. This phase is engaged as soon as the battery charger is activated. Full rated charger current is delivered to the battery bank until the acceptance charge voltage limit is reached. This results in a relatively rapid re-charge.

Generally, a wet cell battery bank should not be charged at a rate which exceeds 25% of its capacity.

BATTERY CHARGING

Gel cell and Advanced AGM batteries can accept a higher rate of charge. Consult the manufacturer for specifications.

Stage 2 - Acceptance Charge The acceptance stage immediately follows the bulk charge stage. During this stage the battery voltage is held constant at the bulk charge voltage limit and the current gradually ramps down. During this stage the battery is accepting its final amount of charge current and the last of the sulfate on the plates is removed.

The acceptance stage lasts until the charge current reaches the transition point. A timer will terminate the acceptance stage if this current level is not reached.

ACCEPTANCE TO FLOAT TRANSITION POINTS	
AC Source Manager20	15 Ampere DC
AC Source Manager25	15 Ampere DC
AC Source Manager30	15 Ampere DC

Maximum acceptance time is 1 hour for wet and AGM cells and 3 hours for gel cells. Gel cell acceptance time can be longer because they are less likely to gas. Expect wet cell batteries to gas somewhat during acceptance, this is a necessary part of the charging process.

NOTE: The acceptance stage timer is not used when Link Instruments control the charger. Refer to the Link Owner's Manual.

Stage 3 - Float Charge When the acceptance stage is terminated, either because the charge current ramped down to the transition point or the timer engaged, the charge current will shut off. The unit monitors the battery voltage while it drifts down from the acceptance charge voltage limit. When it reaches the float voltage set point, the float charge stage is engaged.

The float charge stage holds the battery voltage constant at a preset lower level, where it is safe for long term battery maintenance. During the float charge stage, the full output current of the battery charger is available to operate any DC appliances that may be on the system, while constantly maintaining the float charge voltage.

The battery charger remains in the float charge stage indefinitely until the charger is disconnected from incoming AC power or turned OFF on the unit or with the Remote Control Panel or Link Instrumentation.

Stage 4 - Equalizing Charge This is the only battery charger stage which is not engaged automatically. It must be manually initiated each time. Applying an equalizing charge is possible only with a Remote Control Panel or Link Instrument.

Periodic equalizing is recommended by most wet cell deep-cycle battery manufacturers. There are no firm rules for how often an equalizing charge should be applied. Follow the battery manufacturer's recommendations for equalizing.

BATTERY CHARGING

The equalizing charge is a timed, 8-hour cycle. The cycle can be ended early by interrupting the AC power to the charger at any time during the cycle. Equalizing should only be engaged after the batteries have been fully charged by a normal battery charging cycle.

During this equalizing stage, the battery voltage will increase to the equalize voltage. This will cause the battery bank to gas profusely and will accomplish the following:

1. Removal of residual sulfate. Each time a battery is cycled (discharged and charged), a small amount of sulfate is left on the plates. Over time, this gradual build-up of sulfate will compromise the performance of the battery. By applying an equalizing charge, the sulfate is returned back to the electrolyte, raising the specific gravity and fully exposing the active material of the plates.

2. Bring all cells to the same potential. All lead-acid batteries are made up of individual 2 volt cells. As the battery bank is cycled, slight differences in the cells result in different cell voltages, affecting the overall charge effectiveness. Equalizing brings all cells to the same voltage and the electrolyte in each cell to the same specific gravity.

3. Mixing up of the electrolyte. Electrolyte in battery cells tend to separate into layers of acid and water. The vigorous bubbling action of the battery during equalizing serves to physically mix the electrolyte. Refer to the Remote Control Panel and Link Owner's Manuals for additional cautions on equalizing.

Note: Do not equalize gel cell batteries.

BATTERY CHARGING

W

1. Do not equalize gel cell batteries.

Check remote default settings.

2. Always monitor the equalize charge cycle. *Provide proper ventilation for battery fumes. Do not allow any sparks during equalizing. If one or more cells begin to overflow, terminate the equalize cycle.*

3. Check the battery electrolyte both before and after the equalizing charge.

Do not expose the battery plates to air. Leave the battery caps on while equalizing. Top off after equalizing.

4. Remove all loads from the DC system before equalizing. *Some DC loads may not tolerate the high charge voltage.*

5. With the Remote Control Panel the battery state-of-charge LEDs sequence during equalizing. When the equalization cycle is complete, the charge automatically goes to float and the green float LED battery status light is on. **With Link Instrumentation**, the red charge LED flashes during the equalizing cycle. When the equalization cycle is complete, the charger automatically goes to float and the green float LED is illuminated.

BATTERY CHARGER VOLTAGE SETTINGS

TEMP	TYPE 0	TYPE 1	TYPE 2	TYPE 3
------	--------	--------	--------	--------

INSTALLATION PRECAUTIONS

CAUTION This equipment is **not ignition protected** and employs components that can produce arcs or sparks. To reduce the risk of fire or **explosions, do not install in unvented compartments containing batteries or flammable gasses** or areas in which ignition-protected equipment is required.

WARNING

For continued protection against risk of electric shock, use only the ground-fault circuit interrupter (GFCI) type receptacles detailed in this manual. Other types may fail to operate properly when connected to this inverter, resulting in a potential shock hazard.

CAUTION To reduce the risk of electric shock and prevent premature failure due to corrosion, **do not mount where exposed to rain, dripping or spray.**

CAUTION To reduce the risk of fire, do not obstruct ventilation openings. Do not mount in a zero clearance compartment, overheating may result.

CAUTION *Risk of electrical shock. Both AC & DC voltage sources are terminated inside this equipment.* Before servicing disconnect all inputs and outputs.

Confirm that your shipping carton contains:

- Inverter/Charger
- TSC temperature sensor with 15' cable
- Owners Manual
- Warranty Card
- Jumper for AUX Switch (only used without Remote Control Panel or Link Instrument)
- Wire Nuts

Typical Tools Needed

Flathead and Phillips Screwdrivers
Allen (Hex) Screwdriver (1/8")
Wrench for connecting battery cables (9/16")
Wire Cutters
Wire Strippers
Misc. assortment of wire ties and connectors

Accessories Needed for Installation

Fuse - UL Listed DC Rated slow blow fuse as required by NEC
Electrical wire (10 gauge) for AC input wiring.
Consult NEC for proper size for output wiring.
Battery Cables 1- Positive, 1-Negative
Consult NEC for proper size
DC fuse cable
Mounting Screws (4)



Freedom 20

The Freedom 15D and 20D have dual AC Outputs.

INSTALLATION

CAUTION *Risk of electrical shock. Do not remove cover, no user serviceable parts inside.* Refer servicing to qualified service personnel.

The Freedom Combi is appropriate for installation in recreational vehicles (RV), and other applications.

It is recommended that installation be completed by an authorized Heart Interface technical dealer or experienced electrician.

Key Installation Points

- 1. The unit is designed to mount horizontally** (on a shelf).
- 2. Allow several inches of clearance** around the unit to permit a supply of fresh air to the cooling fan. Do not block any of the vents or louvers. The thermostat controlled fan pulls air from outside the unit. It pulls air across the internal components, particularly the transformer and heat sinks, then out the fan vent.
- 3 Keep the inverter/charger out of the elements and out of direct contact with water or spray.** Failure to do so may result in premature malfunction from corrosion and void the warranty.
- 4 Mount the unit as close to the batteries as possible** but not in the presence of flammable fumes or in an enclosed battery compartment.

WARNING

Do not mount the unit in an enclosed battery compartment. Take precautions to keep dirt and spray off the unit.

5. Keep the overall length of each battery cable less than 10 feet. Do not use frame ground or a ground bonding system as a current carrying conductor. Run the negative(-) cable directly to the battery bank. If the positive (+) and negative (-) cables run parallel to each other, twist the cables together. This will minimize the inductive adverse effects of cable length. Be sure the cable size meets with NEC requirements for your installation.

6. Make sure all wiring conforms to local and national electrical codes. If in doubt, consult with a qualified electrician.

7. To meet electrical codes, a UL Listed DC Rated slow blow fuse must be installed in the positive battery cable within 18 inches of the battery post. This fuse is intended to protect the battery and cables against a short circuit. The inverter is protected internally and will not blow a properly sized fuse.

8. Do not connect the battery until you have read the remainder of the installation section. Observe proper polarity when connecting batteries. Reverse DC polarity will result in damage to the unit and will void the warranty. Use care when making the DC connections.

WARNING

The Freedom Series is not DC reverse polarity protected. Be very careful to connect the negative and positive cables correctly, otherwise damage will result and the warranty will be void.

INSTALLATION

9. Do not back-feed the AC output of the inverter with incoming AC power. A back-feed occurs when AC power from shore power or generator is connected to the output of the inverter. This will damage the inverter and void the warranty. Remember that incoming AC must be fed only to the AC input and never the AC output. Always check for AC voltage before connecting wires to the AC output. Do NOT turn the inverter ON until all AC connections have been made. Back-feeding the inverter voids the warranty.

WARNING

Do not connect incoming AC from any source to the AC output of the inverter. This is known as back-feeding and will damage the unit and void the warranty.

10. Do not connect the AC input to the AC output. This would be equivalent to plugging the battery charger into the inverter. This could occur if the unit's AC output is connected to the entire leg of a circuit breaker panel, then a circuit breaker on that leg is used to feed the battery charger input. This will cause the unit to oscillate ON and OFF when the unit is in inverter mode.

11. Always use proper wire and connectors. The proper battery cable size is critical. Considerable amperage flows in the DC circuit. For the Freedom 10 use 2 AWG (for the Freedom 15, 20, 25 2/0 AWG, for the Freedom 30 3/0 AWG) UL Listed Welding Cable terminated on each with UL Listed or UL Recognized ring terminal connectors. For the terminal, use Thomas & Betts (T&B) part number BAL 2038. Be sure the connectors are attached to the cable using a method approved by the connector manufacturer. For the con-

nections to meet all requirements, T&B recommends that each terminal be crimped in two places with a pressure of 15 tons using a hexagonal die. The T&B die has a code number of 54. After the crimp is made, the barrel of the terminal and the first inch of the cable needs to be covered in UL Listed or UL Recognized heat shrink tubing. Heart Interface recommends a 2-inch length of 3M HDT 0800 tubing. Other heat shrink may be used if it is UL Listed or UL Recognized as long as the manufacturer's directions are followed.

12. If installing in a system which includes an existing battery charger or AC to DC converter, make sure these do not operate from the inverter output AC power. This sets up a power loop which, due to inefficiencies, will quickly drain the batteries.

13. An Auxiliary Switch port is located on the front panel of the unit, covered by a flap. When installing the unit for operation without a Remote Control Panel or Link Instrument, a jumper must be installed in the Aux Switch port. The jumper is shipped in a plastic bag with other installation parts. DO NOT install the jumper until all cable connections have been made.

When using a Remote Control Panel or Link Instrument, the jumper is not used.

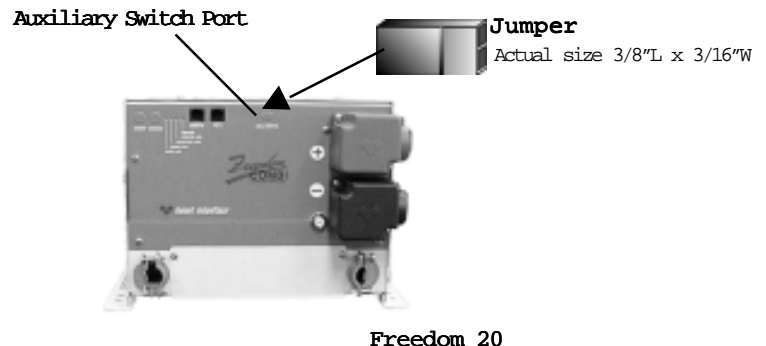

INSTALLATION

Grounding

For safety purposes, the chassis of the inverter/charger must be connected to your AC ground system. Use 8 AWG bare copper or green insulated wire, strip one end and use a screwdriver to secure it to the chassis ground bonding lug on the side of the unit. This wire will connect to the ground in your AC electrical system. Make sure the connection is clean and tight.

The system AC ground bonding terminal is located on the front of the unit under the wiring cover at the bottom of the unit. This connector is for the bare copper or green ground wires from the AC branch circuit supply and to the AC loads or distribution panel. It is important that these AC input and AC output ground wires connect to the AC ground bus in the circuit breaker panels.

Some installations require heavier grounding wire. Conform to local and national electrical codes.

More information on grounding can be found in the National Electrical Code and local electrical codes.



Ground Lug

Note: The battery cables are not connected to the AC ground strip or to the chassis lug of the unit.

Neutral Bonding

For safety purposes and NEC code requirements, the Freedom Combi unit internally bonds the AC output neutral (white) to the AC output ground (green), when the unit is OFF or in the inverter mode. When incoming AC power is applied and the transfer switch is engaged, the internal neutral-to-ground bond is automatically lifted.

When external AC power is applied, the grounding system is connected to the source power ground, where neutral and earth ground are bonded together. This technique insures safety in all conditions and conforms to the requirements of the NEC.

WARNING

Do not connect incoming AC from any source to the AC output of the inverter/charger. This is known as back-feeding and will damage the unit and void the warranty. The Over Temp/Overload and Low Battery LEDs will be blinking rapidly if this condition exists.

INSTALLATION

AC Wiring

The AC wires route through the strain relief mounted in holes on the front of the unit. Use a screwdriver to remove the screws which secure the AC wiring compartment cover plate. Depending upon which model you have, there can be one or two AC inputs and one or two AC outputs within the AC wiring compartment. The labeling for the pigtails is on the front of the unit and is visible when the cover plate is removed. Note: Green wires are connected to the AC Ground Strip.

Black **Ht or Line**
White **Neutral**

Conventional metal strain reliefs are provided. These can be replaced with plastic strain reliefs for additional corrosion resistance or 3/4 inch conduit fittings if the wiring will be routed through a conduit.

Appropriate wire gauges must be used throughout the installation. Refer to NEC specifications.

AC Input: All inputs from other AC sources must be protected by branch circuit rated circuit breakers.

In the United States, no additional circuit breakers are required between the inverter/charger and the loads if the service to the inverter/charger is protected by a 20 ampere branch circuit rated breaker. This also applies to Dual Input models where the inputs may be 20 amperes each. In Canada, 15 ampere branch circuit(s) maximum shall provide the service.

If a 30 ampere service supplies the inverter/charger, additional 20 ampere (15 ampere in Canada) maximum branch circuit

rated circuit breakers will be required between the inverter/charger and the loads.

Feed one or two 3 conductor AC input wire(s) through the strain relief and into the AC wiring compartment. Allow 6 inches of individual insulated black, white and green wire to work with. Strip 1/2 inch of insulation off each conductor and connect to the pigtails: Black to Black, White to White, and Green to AC Ground Strip.

Use the wire nuts provided to make the wire connections. You may chose to use butt splices (not included) to make the wire connections.

AC Output: Depending on the model you have, feed one or two 3 conductor AC output wire groups for the two branch circuit loads through its strain relief. Remember to allow 6 inches of individual insulated black, white and green wire to work with. Strip 1/2 inch of insulation off each conductor and connect to the pigtails: Black to Black, White to White, and Green to AC Ground Strip.

Tug firmly on each connection to make sure they are secure. Later, if the unit is not operating properly, check these connections first. Carefully tuck the wires into the AC wiring compartment. Replace the cover plate.

Dual AC Output

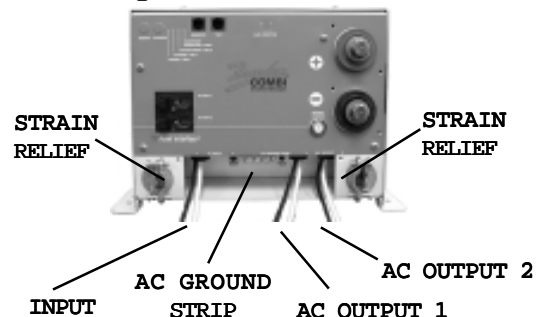

INSTALLATION

Ground Fault Circuit Interrupters

To conform to NEC regulations, certain branch circuits must be equipped with a Ground Fault Circuit Interrupter (GFCI). Please consult the code or a qualified electrician for details. Any such branch circuits must be protected by a brand rated circuit breaker consistent with the GFCI rating. Underwriters Laboratories has tested the following GFCI, and its use is recommended. Receptacle Type:

Pass & Seymour
Catalog Number 1591
Rated: 15 Amps at 120 Volts A C

Remote Control Wiring

If installing a remote panel, route the remote cable and connect to the Remote jack on the front of the unit. Refer to the Remote Control Panel or Link Owner's Manual for more information.

TSC Temperature Sensor

If installing the TSC (Temperature Sensitive Charging) sensor, connect the ring terminal end to the positive battery post, complete the routing of the RJ11 cable (15 feet supplied) and connect the plug end to the TSC jack on the front of the unit.

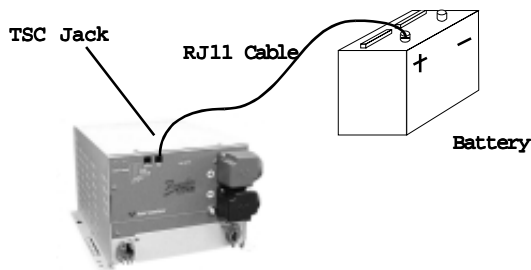

Freedom 20 shown.

DC Wiring

DC wiring is generally very simple, the positive (+, may be red for identification) and negative (-, may be black or yellow for identification) cables from the inverter/charger terminal posts are connected to the house or auxiliary battery. Connection to the engine starter battery is not recommended.

High current will pass through the DC wiring. All wires must be properly sized and all connections clean and tight. It is recommended that the battery cable length does not exceed 10 feet.

Battery cables should be connected to the inverter/charger before any connections are made to the battery. Follow the battery hardware stackup diagram.

- Remove the negative (-) battery cable cover from the unit and attach the battery cable. Tighten the battery terminal bolts to a torque value between 160 inch-pounds and 180 inch-pounds. Replace the cover for the negative terminal before removing the cover for the positive terminal.

Battery Cable Hardware Stackup Diagram

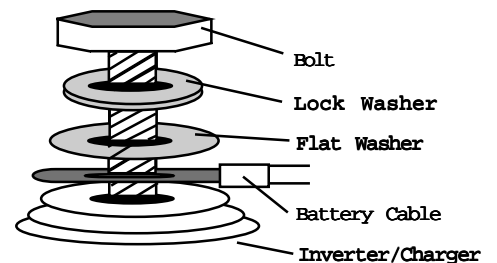

CAUTION Improper stackup may result in excessive heat and damage to the unit.

WARNING

Freedom Inverter/Chargers are not protected against DC reverse polarity. Be very careful to connect the negative and positive cables correctly or damage will result and the warranty will be void.

INSTALLATION

- Remove the positive (+) battery cable terminal cover from the unit and attach the battery cable. Tighten the battery terminal bolts to a torque value between 160 inch-pounds and 180 inch-pounds. Replace the cover for the positive terminal.

The negative (-) cable should be connected directly to the negative post of the house or auxiliary battery bank or the ground side of a current shunt. Tighten securely.

The positive (+) battery cable must be fused and connected to the positive post of the house or auxiliary battery bank, or through a selector switch to one or more battery banks.

A spark may be generated when the final battery connection is made. This is normal; do not be alarmed. However, do not make the final connection in the presence of flammable fumes.

If multiple batteries are used, the interconnecting jumper cables must be the same AWG or larger as those connected to the inverter/charger.

NOTE: If installing in a vehicle, do not use the vehicle frame as the negative conductor.

If multiple battery banks are to be charged, a battery bank selector switch can be installed, allowing the banks to be charged either individually or simultaneously. A solenoid can also be used. The PathMaker Battery Combiner, by Heart Interface, may be used to connect multiple battery banks. The PathMaker battery combiner is available from your Heart dealer.



PathMaker 100, 2 Channel

PathMaker Models

- 100 Amp, 2 Channel
- 100 Amp, 3 Channel
- 200 Amp, 2 Channel
- 200 Amp, 3 Channel



POSITIVE (+)
(Battery Cable
Cover on)

NEGATIVE (-)
(Battery Cable
Cover on)

Freedom 20

INSTALLATION

Battery Cable Fusing

A fuse is required by the NEC to protect the battery and cables. A UL Listed DC rated slow blow fuse must be installed in the positive (+) battery cable, within 18 inches of the battery.

Recommended Fuse: *UL Listed Class T JLLN* with a DC Rating. This fuse with fuse holder is available from your dealer or Heart Interface.

For Freedom 10

- 200 Amp Fuse & Holder PN# 84-4155-00 (C/R)*
- 200 Amp Fuse & Holder PN# 84-4158-00 (R/R)**
- 200 Amp Fuse Only PN# 84-4157-00

For Freedom 15 & 15D

- 200 Amp Fuse & Holder PN# 84-4155-00 (C/R)*
- 200 Amp Fuse & Holder PN# 84-4158-00 (R/R)**
- 200 Amp Fuse Only PN# 84-4157-00

For Freedom 20 & 20D

- 300 Amp Fuse & Holder PN# 84-4156-00 (C/R)*
- 300 Amp Fuse & Holder PN# 84-41554-00 (R/R)**
- 300 Amp Fuse Only PN# 84-4117-00

For Freedom 25

- 300 Amp Fuse & Holder PN# 84-4156-00 (C/R)*
- 300 Amp Fuse & Holder PN# 84-4154-00 (R/R)**
- 300 Amp Fuse Only PN# 84-4151-00

For Freedom 30

- 350 Amp Fuse & Holder PN# 84-4159-00
- 350 Amp Fuse Only PN# 84-4152-00

* Compression / Ring Terminal

** Ring / Ring Terminal

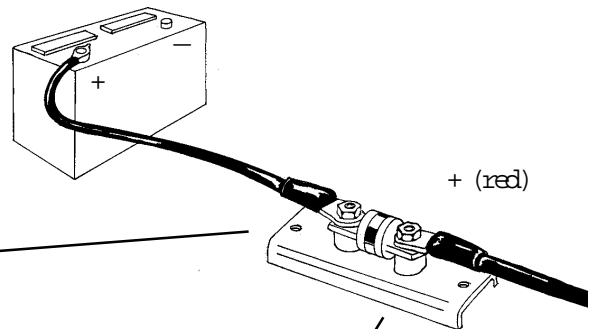

COMPRESSION / RING TERMINAL

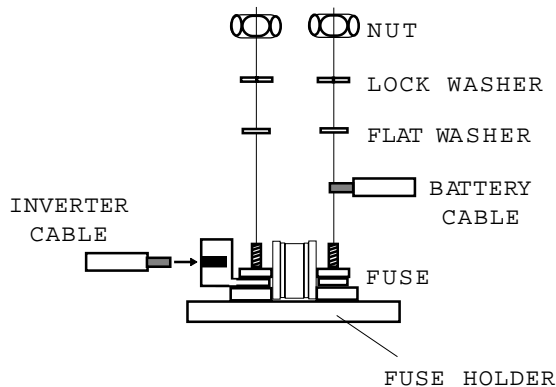

EXPLODED VIEW OF FUSE ASSEMBLY

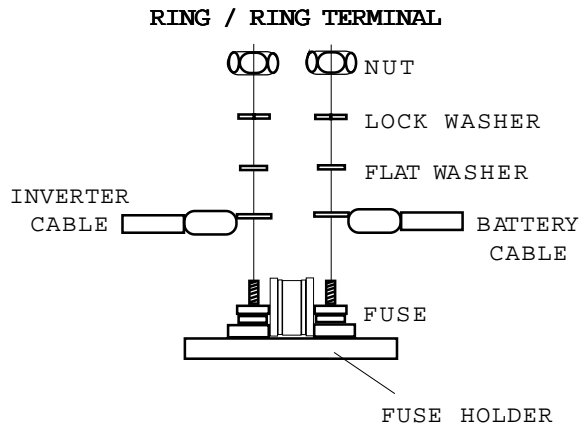

WARNING

Improper stack up of hardware will cause excessive heat and fuse failure. Stack up as shown.

INSTALLATION

Follow these instructions to insure proper start up and confirm that the installation is correct.

1. Check to make sure Invert and Charge are OFF. The INVERT LED should not be illuminated, the CHARGE LED should be blinking (charger ready but no external AC power available). If using a Remote Control Panel or a Link Instrument, make sure inverter and charger are OFF.

2. Check battery polarity. If the unit was connected to the battery with reverse polarity, the unit will be damaged.

3. Check the battery voltage and ensure it is within proper range for the unit (10-15.5 VDC).

4. Install the jumper in the Auxiliary Switch port (AUX SWITCH), if using the inverter without remote. If operating the inverter with a remote, the jumper should **not** be used.

Do not apply shore power or generator power without performing the following steps:

1. Test the inverter function:

• With no loads connected to the output of the inverter, turn the INVERT Switch ON. The INVERT LED should be blinking green. If using a remote, turn ON the inverter with the switch on the Remote Control Panel or Link Instrument.

• The Freedom unit will produce a slight buzz. If using a Remote Control Panel or Link Instrument the INVERT/ CHARGE LEDs will illuminate and the voltage indicator will display the battery voltage. The DC Amps LED will not be lit because the unit is in the idle mode.

WARNING

Do not turn the inverter ON before eliminating any possibility of backfeed.

• Add a load of 7 watts or more to the output of the inverter. A 40 watt incandescent light bulb will work fine. The DC Amps LEDs on the remote will indicate the DC draw from the battery through the inverter.

• Leave the load connected and turn OFF the INVERT mode by pressing the INVERT switch or turn OFF the INVERT mode from the Remote Control Panel or Link Instrument.

2. Test the transfer function:

• Be sure the unit is OFF, the INVERT and CHARGE LEDs are not illuminated. Apply shore power. If there is a back-feed in the installation, the unit will protect itself, the LOW BATTERY and OVERTEMP/OVERLOAD LED will both be blinking rapidly (5 times per second). Do not proceed until the backfeed condition has been corrected.

• Once shore power has been applied to the unit, there will be approximately an 8 second delay. Then the unit should transfer shore power and power the load. If this does not happen, do not proceed. If the LOW BATTERY and OVERLOAD/OVERTEMP LEDs are blinking rapidly or if you are using a Remote Control Panel or Link Instrument, check the panel for back-feed indication. The panel will show an overload condition. Eliminate the back-feed condition.



INSTALLATION

- Testing for backfeed. If a backfeed condition is indicated, disconnect from shore power and disconnect the AC output wires on the inverter. Make sure the inverter is OFF. Apply shore power and measure for voltage between the black and white wires that were attached to the inverter output feeding the electrical panel or loads, not the inverter output wires. If there is voltage on these wires, a back-feed condition exists and must be corrected or damage will result.

3. Test the battery charger function:

- With shore power applied and the transfer switch engaged, the battery charger should be in operation. The CHARGE LED will blink for 8 seconds. After the 8 seconds, the unit will enter the charge mode and the LED will be illuminated. (NOTE: When using Temperature Sensitive Charging, this time may be longer)

NOTE: When AC is available, the unit will automatically default to charge mode without the operator setting the unit in CHARGE mode. It is necessary to press the CHARGE switch OFF, if you do not want to charge.

Verify the charger is working by using a volt meter. The battery voltage should gradually increase. If using a Remote Control Panel, the DC Amps LED indicates the current the charger is putting out and the DC Volts LED indicates an increase in battery voltage.

- Turn the INVERT ON, the green LED should blink. Remove shore power and the inverter should automatically pick up the AC load when shore power is removed.

NOTE: For low power system shut down mode, both the INVERT and CHARGE LEDs must be OFF.

Repeat the test for transfer and battery charger with the generator if you have one.

Congratulations, you have completed a successful installation.



TROUBLESHOOTING LED STATUS

LED Status				Operation Status	Notes
INVERT	CHARGE	LOW BATTERY	OVERTEMP OVERLOAD		
Solid Green	Blinking Green	OFF	OFF	Inverting, Charger ready but no external AC available.	Normal
Blinking Green	Solid Green	OFF	OFF	Inverter is in standby. Battery is being charged.	Normal, charging current limited if AC load exceeds Power Sharing setting.
Blinking Green	OFF	OFF	OFF	Inverter is in standby. Charger manually tuned off.	If AC power is removed and reappplied, the charger will automatically turn ON.
OFF	Solid Green	OFF	OFF	Inverter OFF, Charging.	Reset the inverter by pushing INVERT button. LED should blink.
Solid Green	Blinking Green	Solid Red	*	Inverting, Charger ready but no external AC available. Battery Voltage Warning: 10V < VDC < 15V	Warning. Battery voltage less than 10 or more than 15 volts
Solid Green	Blinking Green	*	Solid Red		but no

TROUBLESHOOTING

GLOSSARY

Alternating Current (AC) An electric current that reverses direction at regular intervals. Sources of alternating current are shore power, generator power, inverter power or household current.

Ampere (Amp, A) The unit of measure of electron flow rate of current through a circuit.

Ampere-hour (Amp-Hr, AH) A unit of measure for a battery's electrical storage capacity, obtained by multiplying the current in amperes by the time in hours of discharge (Example: a battery which delivers 5 amperes for 20 hours delivers 5 amperes times 20 hours, or 100 Amp-Hr. of capacity)

Ampere-Hour Capacity The ability of a fully charged battery to deliver a specified quantity of electricity (Amp-Hr, AH) at a given rate (Amp, A) over a definite period of time (Hr.). The capacity of a battery depends upon a number of factors such as: active material, weight, density, adhesion to grid, number, design and dimensions of plates, plate spacing design of separators, specific gravity and quantity of available electrolyte, grid alloys, final limiting voltage, discharge rate, temperature, internal and external resistance, age and life of the battery (bank).

AGM (Absorbed Glass Mat) Battery A lead acid, maintenance-free battery.

AWG (American Wire Gauge) A standard used to measure the size of wire.

Circuit An electric circuit is the path of an electric current. A closed circuit has a complete path. An open circuit has a broken or disconnected path.

Circuit (Series) A circuit which has only one path for the current to flow. Batteries arranged in series are connected with the negative of the

first to the positive of the second, negative of the second to the positive of the third, etc. If two 6 Volt batteries of 50 ampere-hours capacity are connected in series, the circuit voltage is equal to the sum of the two battery voltages, or 12 Volts, and the ampere-hour capacity of the combination is 50 ampere-hours.

Circuit (Parallel) A circuit which provides more than one path for current flow. A parallel arrangement of batteries (of like voltage and capacity) would have all positive terminals connected to a conductor and all negative terminals connected to another conductor. If two 12 Volt batteries of 50 ampere-hour capacity each are connected in parallel, the circuit voltage is 12 Volts, and the ampere-hour capacity of the combination is 100 ampere-hours.

Combi Freedom Combi_{TM} is a trademark of Heart Interface to indicate a combination inverter/charger.

Current The rate of flow of electricity or the movement rate of electrons along a conductor. It is comparable to the flow of a stream of water. The unit of measure for current is ampere.

Cycle In a battery, one discharge plus one recharge equals one cycle.

Direct Current (DC) Current that flows continuously in one direction such as that from batteries, photovoltaics, alternators, chargers and DC generators.

GLOSSARY

Equalize Charge A controlled overcharge of the batteries which brings all cells up to the same voltage potential, extends the battery life, restores capacity and mixes the electrolyte. This can only be done using the Freedom Remote Control Panel or a Link Instrument.

Gel Cell Battery A type of battery that uses a gelled electrolyte solution. These batteries are sealed and are virtually maintenance-free. Not all sealed batteries are the gel cell type.

GFCI (Ground Fault Circuit Interrupter) A protective device that rapidly de-energizes a circuit when current to ground exceeds a predetermined value.

Ground The reference potential of a circuit. In automotive use, the result of attaching one battery cable to the body or frame which is used as a path for completing a circuit in lieu of a direct wire from a component. This method is not suitable for connecting the negative cable of the inverter to ground. Instead, route the cable directly to the negative terminal of the battery.

LED (Light Emitting Diode) Indicator light.

LINK Instrument These panels monitor single and dual battery banks. Some models provide remote management of Freedom Inverter/Chargers. Available in 4 models: LINK 10, LINK 20, LINK 1000, LINK 2000, LINK 2000R.

NEC National Electric Code

Negative Designating or pertaining to electrical potential. The negative terminal is the point from which electrons flow during discharge.

Ohm A unit for measuring electrical resistance.

Ohm's Law Expresses the relationship between Voltage (V) and Current (I) in an electrical circuit with resistance (R). It can be expressed as follows: $V=IR$. If any two of the three values are known, the third value can be calculated by using the above formula.

Positive Designating or pertaining to electrical potential; opposite of negative. The positive battery terminal is the point where electrons return to the battery during discharge.

Power Sharing The feature of the charger to reduce its output when the AC power being consumed by the charger and external AC loads connected to the output of the inverter are in excess of the input breaker rating.

TSC Abbreviation for Temperature Sensitive Charging. The ability of the charger to adjust its charging voltage based on the temperature sensed at the battery bank if a temperature probe is used.

Volt The unit of measure for electric potential.

Watt The unit for measuring electrical power, i.e., the rate of doing work, in moving electrons by or against an electric potential.

Watt-Hour (Watt-HR, WH) The unit for measuring electrical energy which equals Watts x Hours.

Wet Cell Battery A type of battery that uses liquid as an electrolyte. The wet cell battery requires periodic maintenance; cleaning the connections, checking the electrolyte level and performing an equalization cycle.

SPECIFICATIONS

Model	10 (458 Series)	15 and 15D* (458 Series)	20 and 20D* (458 Series)	25 (458 Series)	30 (458 Series)
Part Number	81-1010-12	81-1510-12 and 81-1520-12	81-2010-12 and 81-2020-12	81-2510-12	81-3010-12
Nominal Battery Voltage	12 VDC	12 VDC	12 VDC	12 VDC	12 VDC
Battery Voltage Range	10-15.5 VDC	10.0 -15.5 VDC (+/-0.2)	10.0 -15.5 VDC (+/-0.2)	10.0 -15.5 VDC (+/-0.2)	10.0 -15.5 VDC (+/-0.2)
Low Battery Cutoff	10 +/-0.5 VDC	10.0 VDC (+/-0.5)	10.0 VDC (+/-0.5)	10.0 VDC (+/-0.5)	10.0 VDC (+/-0.5)
AC Input Voltage Range	Minimum 90 VAC Nominal 130 VAC	Minimum 90 VAC Nominal 130 VAC	Minimum 90 VAC Nominal 130 VAC	Minimum 90 VAC Nominal 130 VAC	Minimum 90 VAC Nominal 130 VAC
Frequency Regulation	50 or 60 Hz Quartz Regulated	50 or 60 Hz Quartz Regulated	50 or 60 Hz Quartz Regulated	50 or 60 Hz Quartz Regulated	50 or 60 Hz Quartz Regulated
Inverter Output Power (Continuous)	1000 VA	1500 VA	2000 VA	2500 VA	3000 VA
Inverter Voltage Regulation	120V +/-5% True RMS	120V +/-5% True RMS	120V +/-5% True RMS	120V +/-5% True RMS	120V +/-5% True RMS
Wave Shape	Modified Sine Wave	Modified Sine Wave	Modified Sine Wave	Modified Sine Wave	Modified Sine Wave
Surge Power	30 Amps	55 Amps	70 Amps	80 Amps	90 Amps
No Load Current Drain (Idle Mode)	.12 Amps	.12 Amp	.12 Amp	.12 Amps	.12 Amps
Power Factor Adjusted	All	All	All	All	All
Full Load Efficiency	85% (60 Hz)	86% (60 Hz)	85% (60 Hz)	87% (60 Hz)	86% (60 Hz)
Peak Efficiency	93%	92%	93%	93%	93%
Protection	Over/Under Utility Voltage, Over/Under Battery Voltage, Short Circuit, Circuit Breaker, Over Temperature, Backfeed	Over/Under Utility Voltage, Over/Under Battery Voltage, Short Circuit, Circuit Breaker, Over Temperature, Backfeed	Over/Under Utility Voltage, Over/Under Battery Voltage, Short Circuit, Circuit Breaker, Over Temperature, Backfeed	Over/Under Utility Voltage, Over/Under Battery Voltage, Short Circuit, Breaker, Over Temperature, Backfeed	Over/Under Utility Voltage, Over/Under Battery Voltage, Short Circuit, Circuit Breaker, Over Temperature, Backfeed
Charging Rate	50 Amps (3-stage)	75 Amps (3-stage)	100 Amps (3-stage)	130 Amps (3-stage)	140 Amps (3-stage)
AC Input Max. Charge Mode)	12 Amps	17 Amps	21 Amps	26 Amps	28 Amps
Bulk Charge Voltage	14.3**	14.3 VDC **	14.3 VDC **	14.3 VDC **	14.3 VDC **
Floating Charge Voltage	13.4 VDC **	13.4 VDC **	13.4 VDC **	13.4 VDC **	13.4 VDC **
Equalizing Charge Voltage	16.3 VDC	16.3 VDC **	16.3 VDC **	16.3 VDC **	16.3 VDC **
Status Panel	Optional Remote or Link	Optional Remote or Link Instruments	Optional Remote or Link Instruments	Optional Remote or Link Instruments	Optional Remote or Link Instruments
Weight	35 lbs.	45 lbs.	45 lbs.	50 lbs.	50 lbs.
Dimensions	13.2"L x 11.5"W x 7.9"H	13.2"L x 11.5"W x 7.9"H	13.2"L x 11.5"W x 7.9"H	13.2"L x 11.5"W x 7.9"H	13.2"L x 11.5"W x 7.9"H
* Dual AC Output ** Variable on unit with Temperature Sensor installed and adjustable by Battery Type selected on the inverter charger control panel or from the Remote Control Panel.					

WARRANTY

Your Heart Interface Freedom 458 Series Combi_{TM} Inverter/Charger is under limited warranty for 30 months from date of purchase.

Terms of this warranty are detailed on the warranty registration card. Please complete this card and return it to Heart Interface to register your warranty.

If the unit requires service, contact Heart Interface by telephone. The service technician will ask for the model and serial number of your unit. Please have this information ready.

**Phone numbers: (253) 872-7225
 (800) 446-6180** (outside 253 area code)

A return authorization number will be required on all returns. This number is issued by the service technician and should be written on the outside of the packaging

You must ship the unit to Heart Interface or a field service center freight prepaid.

The logo features the word "Freedom" in a large, red, cursive script font. A thick red brushstroke underline runs beneath the word. Below the underline, the words "Inverter/Chargers" are written in a bold, black, sans-serif font. A small "TM" trademark symbol is located to the right of the word "Chargers".

**FreedomTM
Inverter/Chargers**